



Mini One is a miniature, positive pressure humidity control device for museum showcases and storage enclosures. This quiet, robust and extremely efficient unit can reliably control relative humidity in individual or multiple enclosures.

## MINI ONE - Active Microclimate Generator for Museum Showcases.

The Mini One satisfies the demanding standards of preventive conservation and modern museum design. It incorporates the most recent developments in electronic humidity control, noise suppression, and pollution abatement.

This positive pressure microclimate control system will typically maintain the relative humidity level in a sealed enclosure to within less than two percent of your target relative humidity. Depending upon the ambient temperature conditions and enclosure construction, stable relative humidity levels of less than thirty five to over eighty percent can be attained.

As the Mini One can be installed in a number of configurations for differing applications, performance characteristics will vary with installations and enclosures. In its most common application, the unit will provide a constant flow of filtered air at a pre-set relative humidity level.

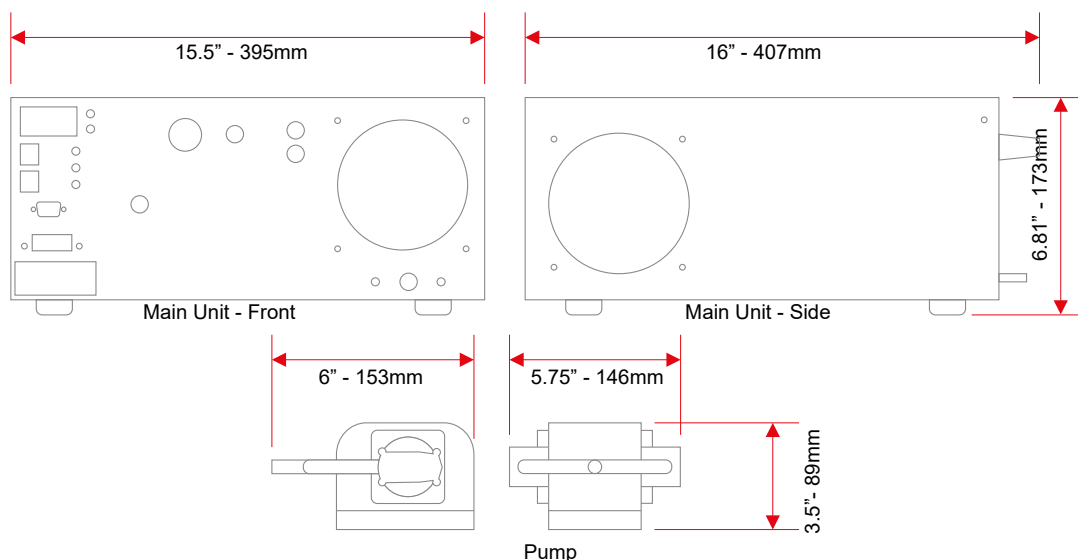



This airflow will maintain stable humidity levels and purge pollutants in a tightly sealed museum display or storage enclosure of up to 10-15 cubic meters / 300-450 cubic feet.

A single Mini One can be used for multiple local showcases, or very enclosure can be controlled with multiple Mini One units.

The Mini One is easy to install, its two modules may be arranged vertically or horizontally to maximize space. The pump may be separated from the main module, or many units may be supplied by a single central filtered air or nitrogen supply. Self limiting controls automatically adjust for differing case sizes, and internal data logger as well as data links for external control, reporting, and data logging are standard.

## AIR PUMP

## OPERATING PRINCIPLES



Ambient gallery air is filtered for pollutants and drawn into the unit. This air is pressurized and directed through a proprietary mechanism that adjusts the relative humidity to the pre-set value. This air is directed through a small flexible tube to an input port in the showcase. Air flow to the enclosure is constant, and in normal applications the air is delivered only at the preset relative humidity.

In normal configurations the unit provides humidity control for a single tightly sealed enclosure, usually not exceeding 10 cubic meters. In these applications the unit will typically provide extremely accurate humidity control; the unit neither adds nor subtracts moisture from the air in the showcase – it gently feeds a steady stream of air into the showcase at the target humidity to displace the existing air and pollutants in the enclosure, which is forced out past gaskets and through small existing leaks.

## INSTALLATION

The Mini One units are usually installed beneath or near the display case, but can also be located up to 15 meters/ 75 feet if necessary.

A typical installation is in positive pressure mode where the machine is connected to the controlled case by a single air hose. If needed the machine can also be setup in recirculating mode.

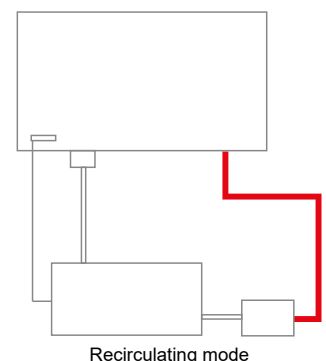
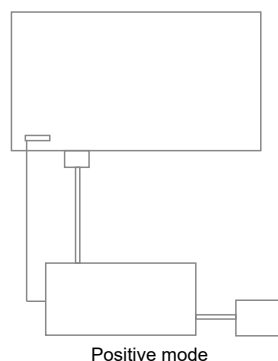

## ▶▶▶ REMOTE MONITORING

The Mini One comes ready for integration with our own [rhmonitoring.com](http://rhmonitoring.com) online service. Existing museum networks may be used to connect the units to the internet, and [rhmonitoring.com](http://rhmonitoring.com) is accessible through any web connectable device. Monitoring can be done from any location.

With this service, the user can read the actual data for relative humidity and temperature, check historical data, examine graphs and change some parameters. Notifications and alarms, such as “Out of Range” and “Low water” may be sent by email as required.

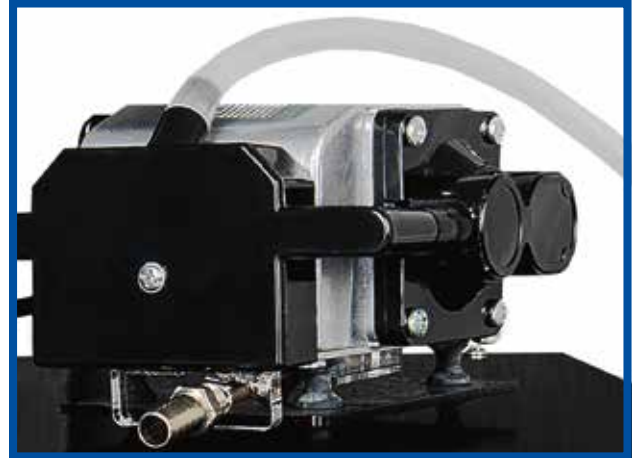

## ▶▶▶ MASTER/SLAVE CONFIGURATION

When it is necessary to control humidity in a single large or leaky showcase, multiple units may be connected in a master/slave configuration. The master unit can be connected to a monitoring system as normal, while the many slave units will provide the desired conditions. up to 5 slave units may be controlled by a single master unit.

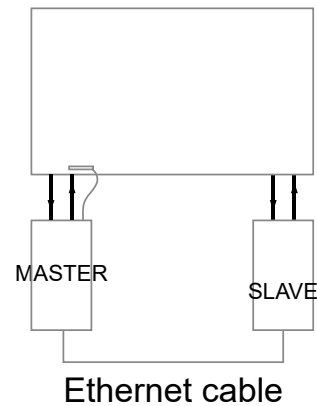

## ▶▶▶ ALARMS AND EXTERNAL WATER RESERVOIR

The Minione is equipped with two external alarms: one for “Out of Range [RH]” and one for “Low water [LW]” status. Those alarms can be connected to any 12 VDC device such as LED light or buzzer. A third connector for an “External pump [EP]” can be used with an optional external water reservoir.





## ►►► SPECIFICATION

**Max. Power Consumption:** 95W  
**Typical Power consumption:** 65W  
**Power supply:** 110 - 240 VAC  
**System Internal Voltage:** 12 VDC  
**Case Material:** powder coated aluminum  
**Shipping weight:** 12 kg  
**Output RH:** 35% - 80%  
**Output Volume:** 24 m<sup>3</sup> /day  
**Max output volume:** 40 m<sup>3</sup> / day  
(contact manufacturer for info)  
**Output pressure:** ~2" H<sub>2</sub>O (600 Pa)

**Operating Temperatures:** 15 to 27 degrees C  
(Ambient temperatures will affect control capacities)

**Data Logging:** Through rhmonitoring.com service

**Element:** Capacitive thin film sensor

**Sensor Reading Accuracy:** ±2% over mid range

**Sensor Repetitive Accuracy:** ±1%

**Biocides:** Copper components, chilled compartments and TiO<sub>2</sub> mesh

