



PRESERVATECH
PRESERVE YOUR PRICELESS TREASURES



Solid State

Microclimate Generator

for Museum Showcases

The PMCG humidity generator is a novel approach for controlling humidity in museum quality display cases. PMCG units are based on solid state technology - unlike other units, they require neither filling nor emptying of reservoirs. Once the machine is setup, the humidity inside the display case can be controlled for years without the necessity of removing condensate, checking the water level, adding water or any other regular maintenance.

PMCG devices can maintain relative humidity from below 20% up to 65% (depends on quality of case and PMCG model), at ambient temperatures of below 0°C up to 40°C. Units come equipped with a WiFi network connection for remote control and data transmission. PMCG units are the of a

modular design; the main unit can be connected to many slave units to achieve the necessary capacity as needed. Installations can economically be custom designed to any application, using only the capacity required. Units are quiet 18-25 dB (depends on fan used) and require no special ventilation.

Machines are built in two different modes, dry power and two arrangements:

DD – provides Dehumidifying Only. DD units are ideal for low level RH applications (eg. 20%) where ambient RH will always be higher than the target RH inside the case. DD units effectiveness at very low rh levels is dependent on showcase design and proper installation.

DH – provides both Humidifying and Dehumidifying. The DH units may be used for all applications. Minimum humidity levels achievable with DH units will depend on ambient conditions but will DH units are less effective at very low humidity's (under 20%).

PMCG 8 – up to 8m³ case volume

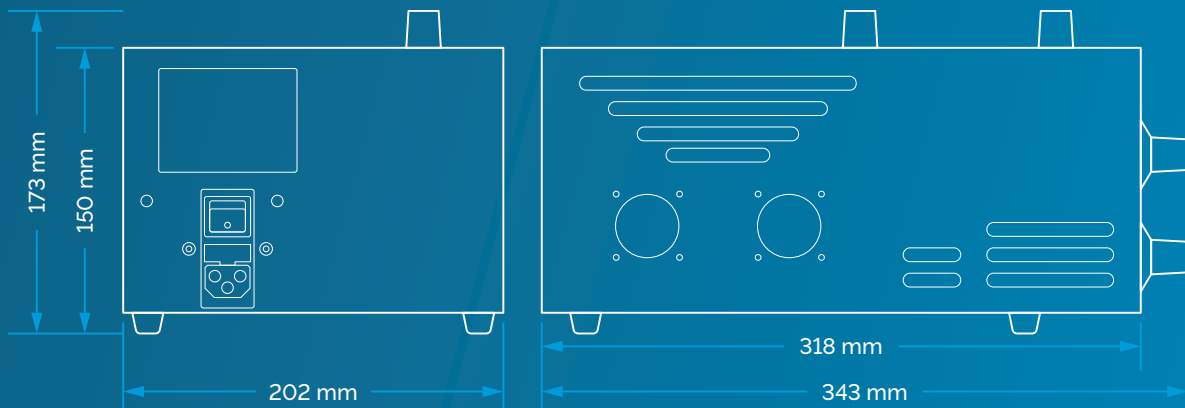

PMCG 4 – up to 4m³ case volume

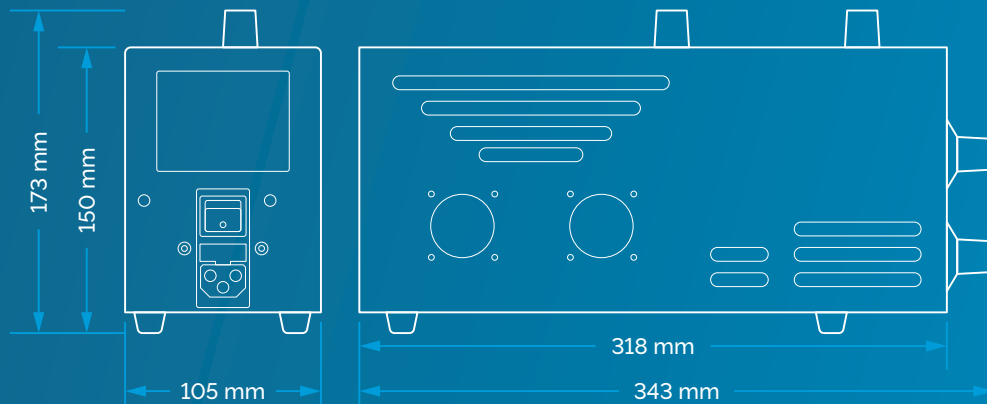

PMCG 2 – up to 2m³ case volume

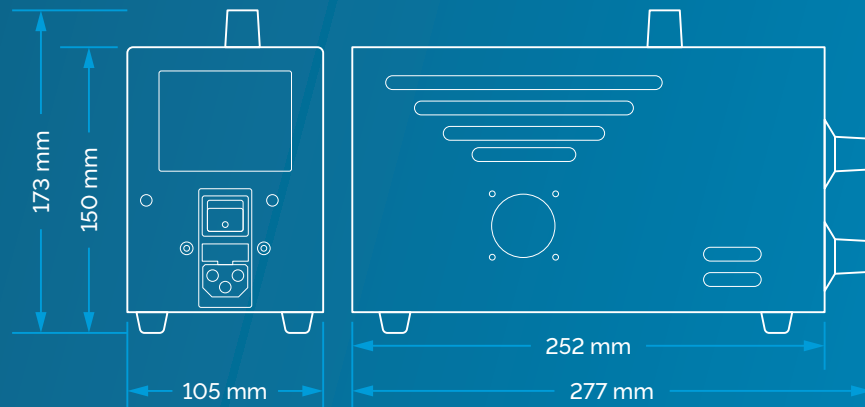

Power Connection	100-240 VAC, 50-60 Hz, 1.5A
Power Consumption	max 16W / 25W / 50W
Achievable RH level	<25% - 60% (depends on mode used and case quality and size)
Permissible Ambient Conditions for Operation	0°C – 60°C
Sensor Accuracy	±3%
Noise Emission	<20dB (25dB if more powerful fan is used)
Weight	1.4 kg / 2 kg / 3kg
Volume of Controlled Enclosure	1 m ³ (up to 2m ³ under some conditions)
Dehumidifying Power DH Model	40g/d, 80g/d, 160g/d (based of DH model, 50%RH)
Dehumidifying Power DD Model	80g/d, 160g/d, 320g/d



INSTALLATION

The PMCG unit should be installed in the close vicinity of a controlled display case (eg. in a cabinet under the case) and is connected to the case with 2 hoses (supply and return, 3/4 inch / 20 mm ID). There is no special recommendation for the enclosure except that it should be adequately ventilated. A standard power outlet is required, 110 VAC or 220 VAC / 50 or 60 Hz.

The PMCG is produced in two arrangements: vertical and horizontal. Choose the best version for your application. The layout of the supply and return hoses leading to the case can have substantial impact on the performance of the unit.

Both hoses should be as short as possible. Avoid bends in the hose and the use of elbows or fittings. Use large radius bends when necessary, and as few as possible. (Any sharp bends, elbows or fittings in the hoses can significantly reduce the PMCG's performance!)

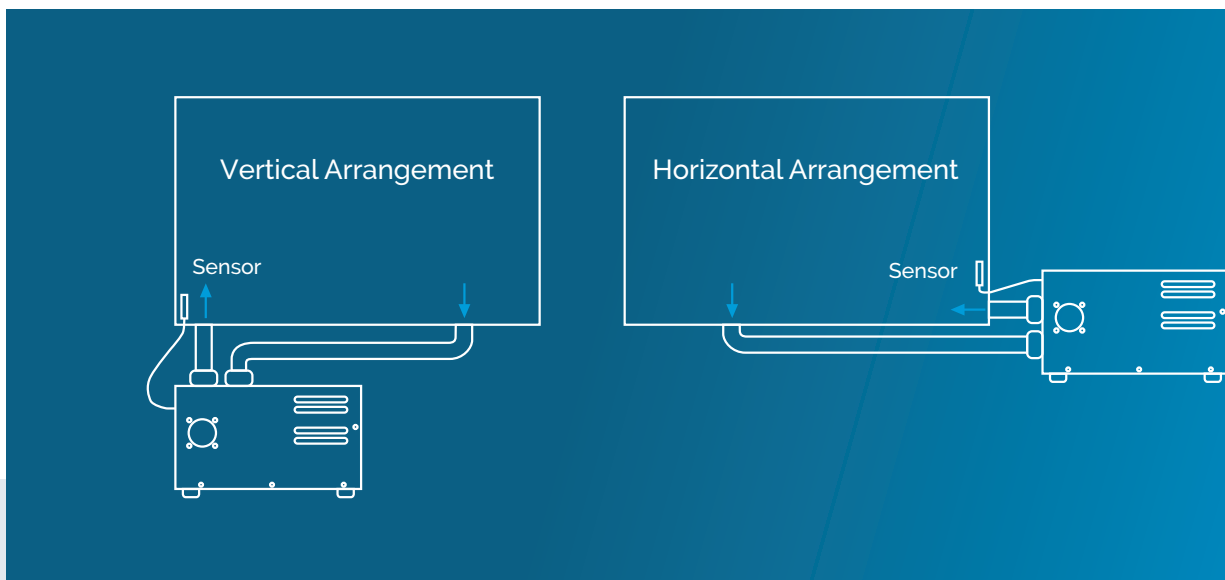

Machines are sold with all the necessary components for a **standard installation**. For some **installations**, an optional **“booster”** fan may be necessary.





EXTERNAL CONNECTION

The PMCG is equipped with an external connector for an OUT OF RANGE alarm. This alarm is a 12 VDC connector to power an LED or other 12VDC device. This alarm will be activated when the RH at the sensor is lower or higher than a value set in the controller by the user.



MASTER/SLAVE CONFIGURATION

When it is necessary to control humidity in a single large or leaky showcase, multiple units may be connected in a master/slave configuration. The master unit can be connected to a remote monitoring system as normal, and up to five slave units can provide extra control capacity to achieve the desired conditions.



REMOTE MONITORING

Existing museum Wi-Fi networks may be used to connect the units to the internet, and rhmonitoring.com is accessible through any web connectable device. Monitoring can be done from any location. Using rhmonitoring.com, an operator can read the current relative humidity and temperature conditions, check historical data, examine graphs and change certain parameters. Notifications and alarms, such as "Out of Range" may be sent by email as required.



MANUAL