

AIR PUMP FOR MINI ONE UNIT OR FILTERING SYSTEMS

Air pump can be supplied in two versions: standard and with noise dampening cover.

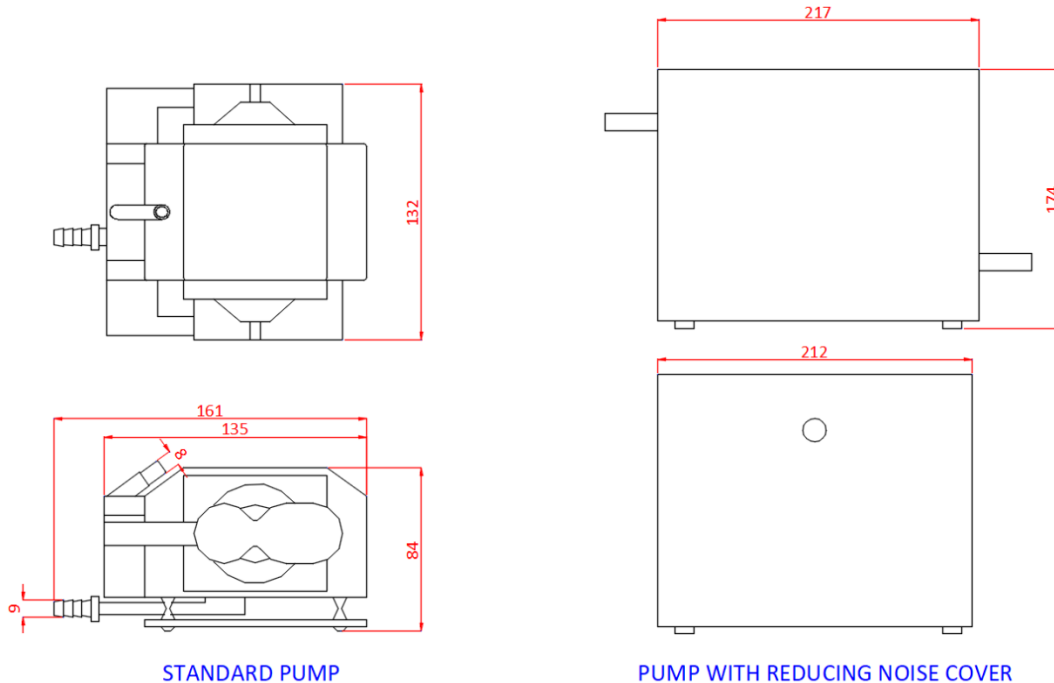

STANDARD PUMP

PUMP WITH REDUCING NOISE COVER

PUMP IS INTENDED FOR USE WITH PRESERVATECH'S PRODUCTS. PRESERVATECH DOES NOT TAKE RESPONSIBILITY IF PUMP IS USED WITH OTHER DEVICES.

- **Voltage:** 110 or 220 V AC
- **Power:** 8W
- **Air flow:** ~1500 l/h
- **Noise:**
 - o Standard Pump: 35dB (with hoses connected)
 - o With cover: < 22dB (with hoses connected)

Power Cord ends with IEC C14 male connector to direct connect with Mini One unit, to use with filtering system, additional female IEC C13 cable is needed (standard computer power cable)

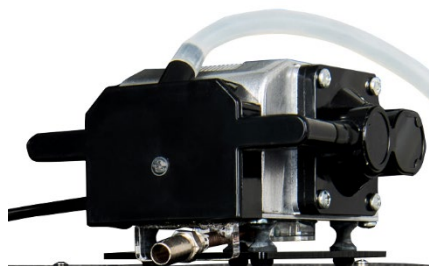

CE DECLARATION OF CONFORMITY

Product: AIR PUMP

Description: AIR PUMP assisting airflow in Mini One humidity generator and/or in filtering system.

Manufacturer: Preservatech Europe sp z o.o. Rowna 1, 85-846 Bydgoszcz

Country of origin: Poland

The above-mentioned product complies with following regulation:

EU Low Voltage Directive 2006/95/EC

EU Electromagnetic Compatibility Directive 2004/108/EC

Harmonised Standards: EN 60335-2-98:2003 + A2:2008, EN 61000-6-3:2007 + A1: 2011, EN 61000-6-1: 2007

Signed Mar 5, 2021 in Bydgoszcz



Jan Maternicki
President