



polystar® impulse generator 120 GE with model 300 D welding tongs



polystar® model SFZ welding tongs



polystar® model DS welding tongs

Last revised 04/2014



Table of contents

1. Figures3

1.1. Important safety instructions4

1.2. Correct use5

2. General information.....5

2.1. Data for the polystar® impulse generator.....5

2.2. Use.....6

2.3. Start-up and operation6

2.3.1. Practical tips.....7

2.3.2. Replacing the polystar® welding tongs7

2.3.3. Adjustable contact pressure of the polystar® welding tongs7

3. Fault detection and troubleshooting8

4. Maintenance8

4.1. Replacing the heater elements.....9

5. Emissions.....10

6. Transport.....10

7. Disposal10

7.1. ... in Germany.....10

7.2. ... in other EU countries.....10

8. Spare parts list11

9. Key.....13

10. Circuit diagram14

11. EC Declaration of Conformity.....15



1. **Figures**

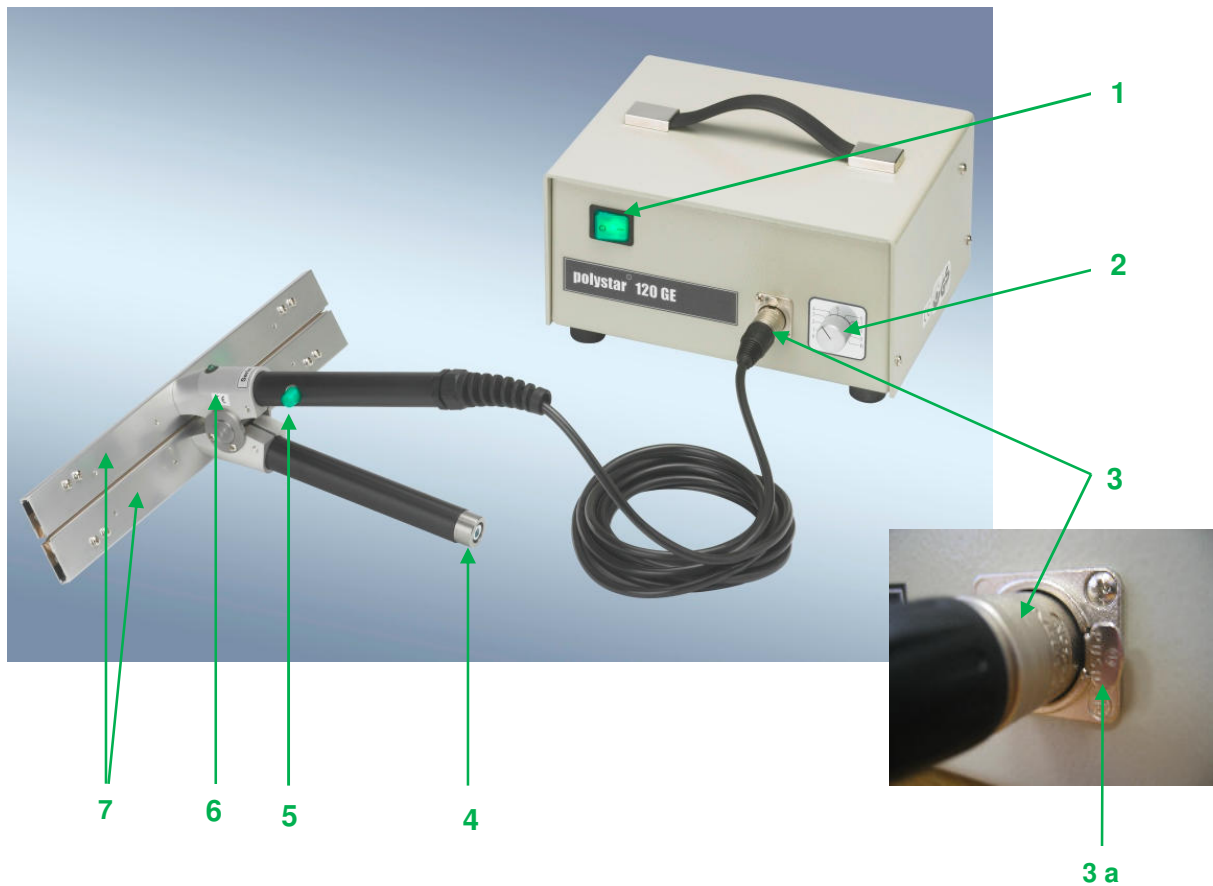

- 1 Rocker switch, green (On/Off switch)
- 2 Metal knob (setting for the length of the thermal impulse)
- 3 Connector for welding tongs
- 3 a Locking key for output socket
- 4 Adjusting device for contact pressure
- 5 Green push-button (triggers the thermal impulse)
- 6 Green LED (shows the thermal impulse)
- 7 Strip-heater carrier with heater elements

2. Important safety instructions

- Read the operating instructions carefully before starting work with the **polystar®** impulse generator.
- Pay attention to the safety instructions.
- Make sure that the mains voltage is the same as the device voltage before connecting the **polystar®** impulse generator.
- The device voltage can be found on the rating plate on the rear of the device.
- Do not reach in between the strip-heater carrier (jaw).
- Do not place the mains plug in water or any other liquids.
- Do not bend the mains lead or place this on hot surfaces.
- Following intense use of the impulse generator certain surfaces, particularly the strip-heater carrier, may be hot as a result of the process. This also holds true after the impulse generator has been switched off.
- Do not leave the **polystar®** impulse generator unattended when switched on.
- Switch the **polystar®** impulse generator off during longer interruptions to use.
- Do not place any combustible items on the **polystar®** impulse generator or welding tongs.
- Repairs may only be carried out by qualified personnel.
- All warranty claims and the product liability will be forfeited with an incorrect use of the device.
- Disconnect the mains plug before all maintenance, repair or cleaning work.
- The mains plug is a mains isolating link and must be able to be checked directly by the operating personnel during work on and with the impulse generator. Ensure unhindered access at all times.
- Non-ionising radiation is not specifically generated but is only emitted technically by the electrical equipment (e.g. by transformers). Furthermore, the device has no strong permanent magnets. If you observe a safety gap of 30 cm (distance between the field source and implant) any negative effects on active implants (e.g. pacemaker, defibrillators) can very likely be ruled out.
- The **polystar®** impulse generator is not explosion-proof and does not fall under any IP protection class.



3. Correct use

- This product is a piece of technical equipment. It may only be used at work.
- Only ever use films (packaging) that do not release any hazardous emission during sealing.
- Only ever use films (packaging) that do not react critically with the sealed products.
- Only ever use the **polystar®** impulse generator in dry areas.
- Do not use in wet, dusty or potentially explosive areas.
- The **polystar®** impulse generator is only suitable for sealing thermoplastic films or other PE-coated materials.
- Only ever trigger thermal impulses when the film to be sealed is on/between the heater element(s).
- Do not place any other materials or objects between the heater elements.
- Use only a damp cloth or air jet cleaner to clean the outside of the **polystar®** impulse generator.

4. General information

This portable film sealer consists of the **polystar®** impulse generator 120 GE and welding tongs.

This film sealer works according to the thermal impulse principle and is ready for immediate use without heating up.

Each welding tongs is equipped with two strip-heater carriers (jaws) that contain the heater elements.

4.1. Data for the polystar® impulse generator

Description:	polystar® impulse generator 120 GE	
Manufacturer:	RISCHE + HERFURTH GMBH, Hamburg	
Power supply:	230 V / 50 Hz	
Current drain:	approx. 1.9 A / 3.7 A	
Current consumption:	approx. 430 W / 860 W	
Welding tongs:	Working width 150 - 300 mm: 21 V Working width 400 - 600 mm: 42 V	
Impulse generator dimensions:	approx. 246 x 195 x 135 mm	Weight: approx. 6.8 kg
Welding tongs dimensions:	approx. 160, 210, 310, 410, 610 x 200 x 65 mm	Weight: approx. 0.7 – 1 kg



4.2. Use

This **polystar®** impulse generator 120 GE in combination with the **polystar®** welding tongs can be used to safely seal all standard thermoplastic films (e.g. polyethylene) as well as composite films in a tube and bag shape.

Max. PE film thickness:	2 x 0.30 mm
Seal width:	3 mm
Seal length (depending on tongs):	150 mm 200 mm 300 mm 400 mm 600 mm

4.3. Start-up and operation

Position the **polystar®** impulse generator with the welding tongs so as to allow ergonomic working. Furthermore, the stability of the impulse generator must be guaranteed at all times.

Plug the connector for the welding tongs into the output socket on the front of the impulse generator. The connector must be heard to lock into place.

Plug the impulse generator's mains plug into the wall socket.

Switch the rocker switch (green) on the front of the device on.

Turn the metal knob to position "1" on the scale. The sealing time is infinitely variable.

Take the welding tongs in your hand. Press the handles together to open the strip-heater carrier.

Place the film to be sealed between the strip-heater carriers (jaws) and close the tongs. To trigger the sealing impulse, press the green push button on the upper handle of the welding tongs with your thumb. The green LED comes on. Keep the push button pressed until the green LED goes out.

The sealing impulse ends when the green LED goes out. The cooling phase begins immediately after this, during which the film material must be left to cool down under pressure. The welding tongs should not be opened beforehand.

The cooling phase should be counted in seconds by the user and should be at least 3 seconds.

The sealing process is completed at the end of the cooling phase.

Now open the welding tongs and remove the sealed film material.

If no satisfactory result is found when checking the seam, turn the metal knob for the sealing time one setting higher. You may have to repeat the procedure several times.

Note: in order to achieve a good seam, do not set the sealing time higher than is necessary. Even though a higher setting can also produce good results it places too much load on the heater element. This in turns leads to premature wear.

4.3.1. Practical tips

Reduce the thermal impulse for more than ten consecutive seals (continuous operation). This reduces the residual heat that accumulates in the heater elements and minimizes wear.

Use films with the specified sealing seam length wherever possible. If narrower films are used, perform the sealing on alternate sides (right, left, center). This spreads the load over the heater elements.

You can prolong the service life of the heater elements by lightly lubricating the Teflon coating at regular intervals. Our **polystar®** silicone paste is available under the order no. 111 300.

If the device is used regularly the Teflon coating should be lubricated once a week in the evenings so that the silicone paste can soak in over night. A thin film of silicone is sufficient.

4.3.2. Replacing the polystar® welding tongs

The three-pole connector is secured in the output socket by a catch. This lock has to be released on the right side of the output socket when replacing the welding tongs. Press the locking key in and pull the connector out of the impulse generator at the same time.

4.3.3. Adjustable contact pressure of the polystar® welding tongs

The contact pressure of **polystar®** welding tongs can be adjusted to different film thicknesses and materials. A corresponding adjustment device has been integrated in the lower handle of the tongs. You can easily adjust the contact pressure to your individual requirements with a **size 5** Allan key. Turn to the right to increase the contact pressure and to the left to reduce this.

The contact pressure has been set to an average film thickness in the factory. An optimum contact pressure alongside the correct sealing and cooling times is absolutely necessary in order to achieve a good seam. Changing the contact pressure always affects the quality of the seam.

5. Fault detection and troubleshooting

In case you do not press the green button enough in accordance with the pre-selected Heat impulse, you will hear an acoustic error signal. Please check and repeat the welding process.



Unplug the device from the mains before opening!

If the **polystar**® film sealer no longer seals bags, check the mains socket.

A qualified person should also check the fine-wire fuse in the power outlet. The housing does not have to be opened for this.

Damage to the Teflon coating (holes, dark discolorations) is a sign that the strip-heater has burnt out. Change the heater elements if this is the case (see assembly instructions on page 9)

Please note that wear parts (heater element, strip-heater, Teflon tape) are excluded from the warranty.

All other faults have to be located and remedied in a service center. You can also send us the **polystar**® impulse generator together with the welding tongs for repair.

6. Maintenance







Heater elements may only be replaced by qualified persons. Observe the following assembly instructions to the word.

We use Teflon tape for the heater elements on account of its high temperature stability. It also stops the film from sticking.

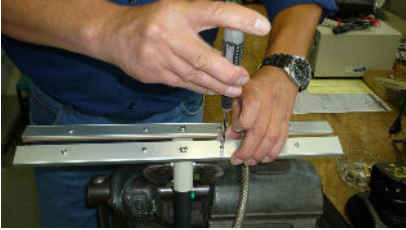
If the strip-heater has burnt out, the complete heater element has to be replaced.

6.1. Replacing the heater elements

You will need the following tools to replace the heater elements: flat nose pliers, Philips screwdriver, slotted screwdriver.

		
<p>Step 1: Loosen the four Philips screws on the strip-heater carrier (jaw) screen.</p>	<p>Step 2: Remove the strip-heater carrier screen.</p>	<p>Step 3: Loosen the outer screws of the terminal plug and pull out the ends of the strip-heater.</p>
		
<p>Step 4: Take a new heater element. Thread the end of the strip-heater through the terminal plug.</p>	<p>Step 5: Tension the terminal plug by pressing it against the strip-heater tension spring. Tighten the screw of the terminal plug.</p>	<p>Step 6: Repeat the procedure for the other end of the strip-heater. Then pull the end of the strip-heater through the terminal plug with the flat nose pliers and pull tight.</p>
<p>Step 7: Bend over the protruding ends of the strip-heater so that they do not make contact with any metal (accidental ground!). Pay attention to the proper fit of the terminal plugs (tensioned)!</p>		<p>Step 8: Then retighten the strip-heater carrier screen. Repeat this procedure with the other strip-heater carrier if necessary.</p>
<p>Note: The terminal plugs must exert a slight tension on the strip-heater to compensate the elongation of the strip-heater through the thermal impulse.</p>		

7. Emissions

polystar® film sealers are almost silent when in operation. The workplace noise is below 70 dB(A).

Gases and vapors, e.g. sealing fumes, are not produced if the device is operated correctly and when sealing thermoplastic films and PE-coated composite films.

8. Transport

The **polystar®** impulse generator 120 GE should be transported by the handles provided for this purpose.

The **polystar®** welding tongs can be transported by their handles.

9. Disposal

9.1. ... in Germany



In accordance with the German Electrical and Electronic Equipment Act (ElektroG), all used electrical and electronic equipment that is put on the market has to be disposed of correctly. The device can be disposed of at the local waste recycling center.

WEEE Reg.No.: DE 48588228 (ElektroG)

In accordance with the German Packaging Ordinance (5th amendment of the VerpackV), the transport packaging is licensed by our company in Germany. Please dispose of the delivered packaging correctly in the corresponding resource recovery cycles.

9.2. ... in other EU countries

Please observe the laws and regulations applicable in your country.

10. Spare parts list

polystar® impulse generator 120 GE

Order number	Item
20365 A	Chassis
20366B	Hood
70614	Power outlet, with interference filter and fuse
70127	Fuse 6.3A/250V/5x20, semi time-lag (f1)
70566	PE insulating bush
70567	Flat plug bush
70568	Flat plug
70651	Fitted power outlet mains lead, straight
70692	Adjusting knob with cap and nut cap
70021	Cable lug
70031	Rubber foot 25 Ø, 14 high
70045	Rocker switch with lamp, green, (a1/h1)
70684	Control circuit board RM (u1)
70590	Socket, 3-pole (bu1)
70479	Varistor
70694	Insulating sleeve, black
70506	Transformer 5621A (m1)
70621	Handle with caps
70658	Terminal plug, 2-pole
70698	Terminal plug, 4-pole

polystar® welding tongs 150 - 600 D, 300 - 600 SFZ, 150 + 300 DS

Order number	Item
60100	Cheese-head screw M 2.5 x 6 DIN 84 (for terminal plug)
60117	Oval head screw M 3 x 8 DIN 7985 (for carrier/collar)
60161	Oval head screw M 3 x 6 DIN 7985 (for tension spring)
70023	Pressure contact DK 40/41 A complete
70591	Connector, 3-pole (bu2)
70025	Cable, black, 2 x 1
70026	LED, green, HP 5082/4850
70028	Insulating paper disk
70122	Resistor 750 Ohm, 1/3 w
70535	Clip for green LED

Order number	Item
H33192	Strip-heater carrier 150 D + DS
H33192A	Strip-heater carrier 200 D
H33192B	Strip-heater carrier 250 DS
H33192C	Strip-heater carrier 300 D
H33192D	Strip-heater carrier 400 D
H33192G	Strip-heater carrier 600 D
H33193	Strip-heater carrier screen 150 D + DS
H33193A	Strip-heater carrier screen 200 D
H33193B	Strip-heater carrier screen 250 DS
H33193C	Strip-heater carrier screen 300 D
H33193D	Strip-heater carrier screen 400 D
H33193G	Strip-heater carrier screen 600 D
H33294A	Strip-heater carrier complete, 150 D + 150 DS
H33294B	Strip-heater carrier complete, 200 D
H33294C	Strip-heater carrier complete, 250 DS
H33294D	Strip-heater carrier complete, 300 D + 300 SFZ
H33294E	Strip-heater carrier complete, 400 D + 400 SFZ
H33294F	Strip-heater carrier complete, 600 D + 600 SFZ
H41043A	Tube handle top
H41044	Tube handle bottom
H46881	Insulating bush 4-6881
H46882	Terminal plug, brass, 4-6882
H46883	Insulating plate to drawing, 4-6883
H46884	Strip-heater tension spring 4-6884
H47049-15	Heater element 150 D + DS
H47049-20	Heater element 200 D
H47049-25	Heater element 250 DS
H47049-30	Heater element 300 D + SFZ
H47049-40	Heater element 400 D + SFZ
40097-60	Heater element 600 D + SFZ
H51117A	Drive screw, to drawing, 5-1117A
H51118	Arbor, to drawing, 5-1118
H51132	Green deco knob, for push-button switch
H51119B	Bearing washer, to drawing, 5-1119B
41149	Tension spring, to drawing , R 4-1149
41150	Clamp bolt, to drawing, R 4-1150
41151	Spring washer, to drawing, R 4-1151



11. **Key**

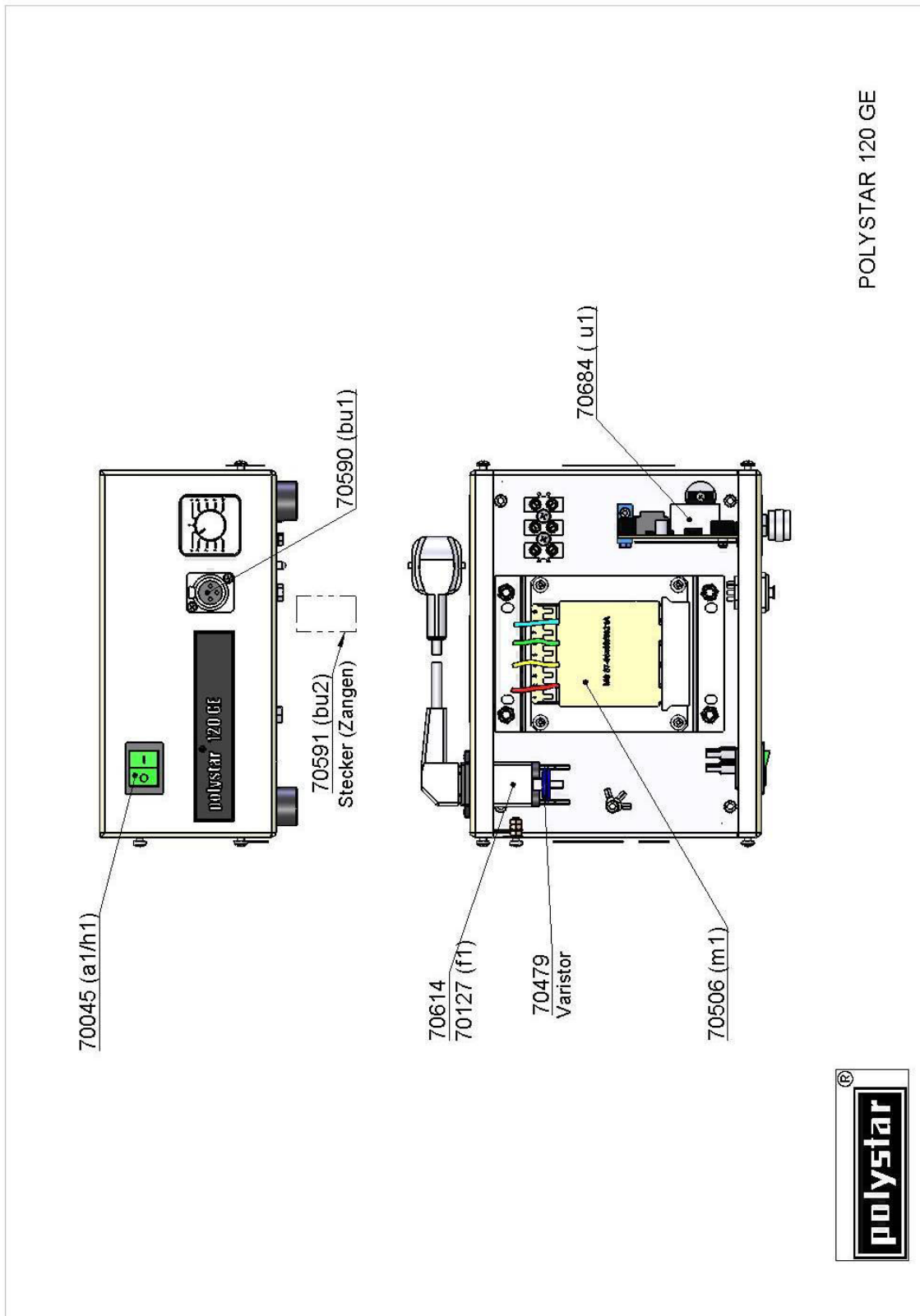

12. Circuit diagram

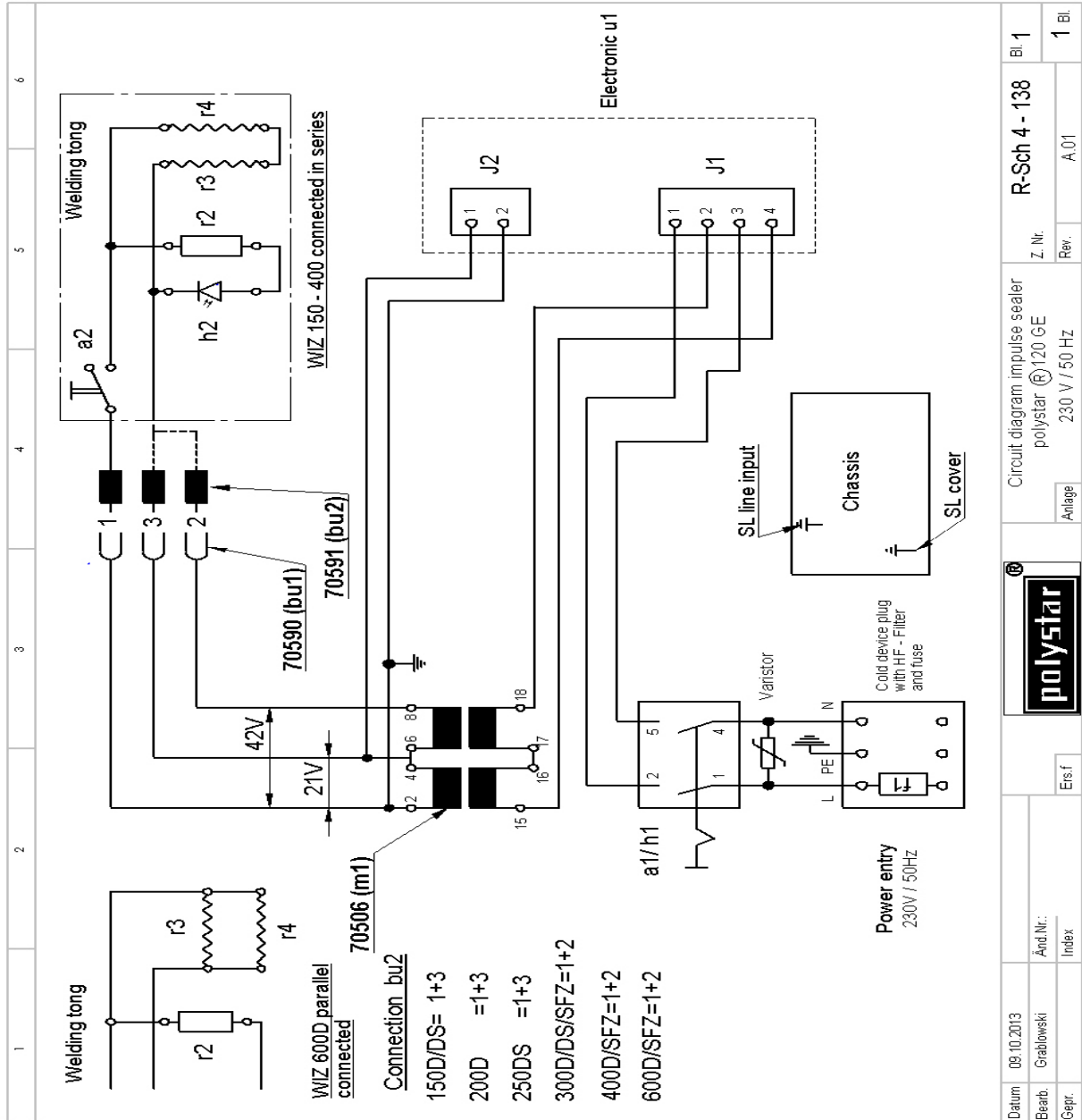

13. EC Declaration of Conformity

The manufacturer RISCHE + HERFURTH GMBH
Kedenburgstraße 53 - 59
22041 Hamburg

herewith certifies that the following product

polystar® film sealer model:
polystar® impulse generator 120 GE

complies with all pertinent provisions of the **directive on machinery (2006/42/EC)** and the **directive relating to electrical equipment designed for use within certain voltage limits (2006/95/EC)** as well as relevant amending directives (CE labeling).

The product was also subjected to an occupational safety test (GS test) by the following testing authority:

Test certificate no. NV 13057
Deutsche Gesetzliche Unfallversicherung e.V.
Prüf- und Zertifizierungsstelle
Nahrungsmittel und Verpackung
Fachbereich Nahrungsmittel
Dynamostraße 7 - 11
68165 Mannheim

Person responsible for the documentation: Adalbert Grablowski, tel.: 040-65 69 03-83

Hamburg, 24 April 2013

ppa. Jürgen Symanzik

RISCHE + HERFURTH ^{GM}
Maschinen- und Apparatebau
Kedenburgstraße 53-59
D-22041 Hamburg
Tel. 040 / 65 69 03-0
Fax 040 / 65 61 890

ppa. Gaby Aldag

